

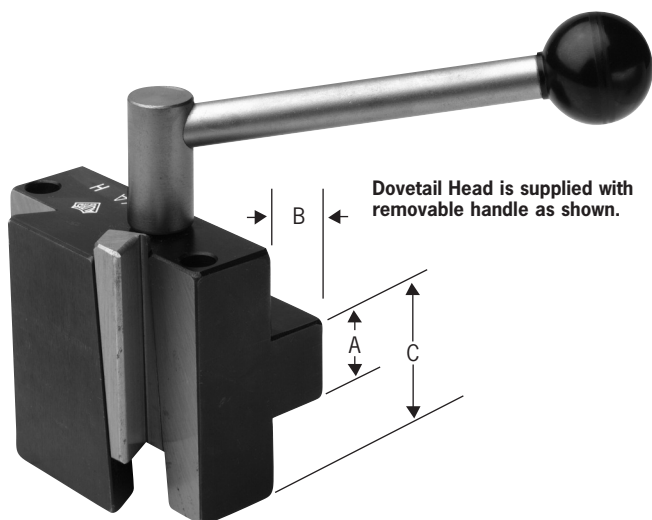

BXA SERIES			CXA SERIES			CA SERIES			DA SERIES			EA SERIES		
ORDER # BXA-77 PRICE EA. \$200.00			ORDER # CXA-77 PRICE EA. \$242.00			ORDER # CA-77 PRICE EA. \$247.00			ORDER # DA-77 PRICE EA. \$274.00					
A	B	USED WITH BLADE WIDTHS	A	B	USED WITH BLADE WIDTHS	A	B	USED WITH BLADE WIDTHS	A	B	USED WITH BLADE WIDTHS			
1 7/32	2	.093 – .120 – .187	1 7/32	2	.120 – .160 – .187	1 7/16	2 1/2	.120 – .187 – .250	1 17/32	2 5/8	.120 – .187 – .250			
SGIH 26-2/-2PS*			SGIH 26-3/-3PS*			SGIH 32-3/-3PS*			SGIH 32-3/-3PS*					
.087 or .093 x 1.0			.120 x 1.0			.120 x 1.25			.120 x 1.25					
REGULAR		POSITIVE STOP	REGULAR		POSITIVE STOP	REGULAR		POSITIVE STOP	REGULAR		POSITIVE STOP			
\$86.00		\$108.00	\$90.00		\$109.00	\$100.00		\$116.00	\$100.00		\$116.00			
SGIH 26-3/-3PS*			SGIH 26-4/-4PS*			SGIH 32-5/-5PS*			SGIH 32-5/-5PS*					
.120 x 1.0			.160 x 1.0			.187 x 1.25			.187 x 1.25					
REGULAR		POSITIVE STOP	REGULAR		POSITIVE STOP	REGULAR		POSITIVE STOP	REGULAR		POSITIVE STOP			
1 Each		1 Each	1 Each		1 Each	1 Each		1 Each	1 Each		1 Each			
\$90.00		\$109.00	\$90.00		\$109.00	\$101.00		\$129.00	\$101.00		\$129.00			
SGIH 26-5/-5PS*			SGIH 26-5/-5PS*			SGIH 32-6/-6PS*			SGIH 32-6/-6PS*					
.187 x 1.0			.187 x 1.0			.250 x 1.25			.250 x 1.25					
REGULAR		POSITIVE STOP	REGULAR		POSITIVE STOP	REGULAR		POSITIVE STOP	REGULAR		POSITIVE STOP			
\$90.00		\$129.00	\$90.00		\$129.00	\$101.00		\$129.00	\$101.00		\$129.00			
ORDER # WSA-7 PRICE EA. \$49.50			ORDER # WSA-8 PRICE EA. \$50.50			ORDER # WSA-9 PRICE EA. \$55.20			ORDER # WSA-10 PRICE EA. \$61.25					
ORDER # BXA-HA* PRICE EA. \$12.60			ORDER # CXA-HA* PRICE EA. \$13.20			ORDER # CA-HA* PRICE EA. \$15.60			ORDER # DA-HA* PRICE EA. \$19.25					

Universal Mounting Aloris Super-Precision Single-Dovetail Heads



The rapid tool-changing versatility and accuracy synonymous with the name Aloris, is now available to users of lathes with turret tool posts or any open slot mounting arrangement. The head is also drilled for mounting on other types of tool carriages. The newly designed models of super-precision single-dovetail heads, accepts any of the wide range of tool holders in the same series, providing quick tool changing flexibility and repeat accuracy at the flick of a handle-one quarter turn locks holder in working position within .0001 inches of preset position everytime. Costly time loss due to repetitive realignment is eliminated. The socket wrench handle, included in the basic head price, is removable for possible clearance requirements when used on CNC lathes.

ORDER #	PRICE EA.	DIMENSIONS		
		A	B	C
BXA-H	\$407.00	7/8	3/4	1 11/16
CXA-H	\$450.00	1"	3/4	1 15/16
CA-H	\$508.20	1 1/4	1"	2 5/16
DA-H	\$653.40	1 1/2	1 1/4	3 1/4