

ALORIS AT-19 ADJUSTABLE KNURLING HOLDER

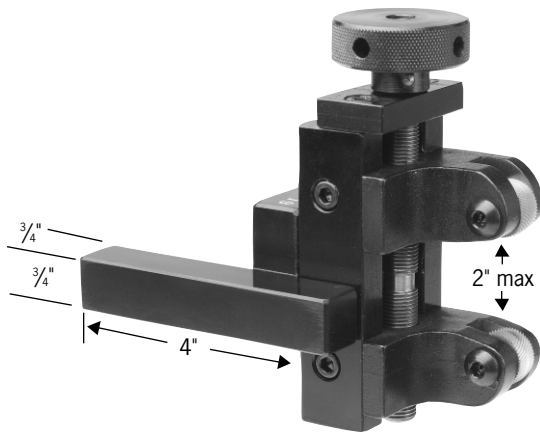

...excellent knurling, with approach adjustability, is provided with the newly designed AT-19 knurling holder. The AT-19 is self-centering and is adjusted by means of a conveniently located knurled knob, providing the ideal near-vertical-axis approach angle for a wide range of stock diameters. Spindle and cross-slide pressure are minimal, thus knurling of thin wall tubing is easily performed.

The Aloris AT-19, which is designed for use in any standard turret tool post or other open-slot holder, is also available with dovetail mounting (series 19) to fit Aloris tool posts. Precision ground, 3/4" O.D. x 3/8" wide, high-speed medium diamond knurls are supplied unless otherwise specified.

ORDER #	AT-19
PRICE - EACH	\$308.00

ALORIS AT-20 COMBO CNC BAR PULLER KNURLING TOOL

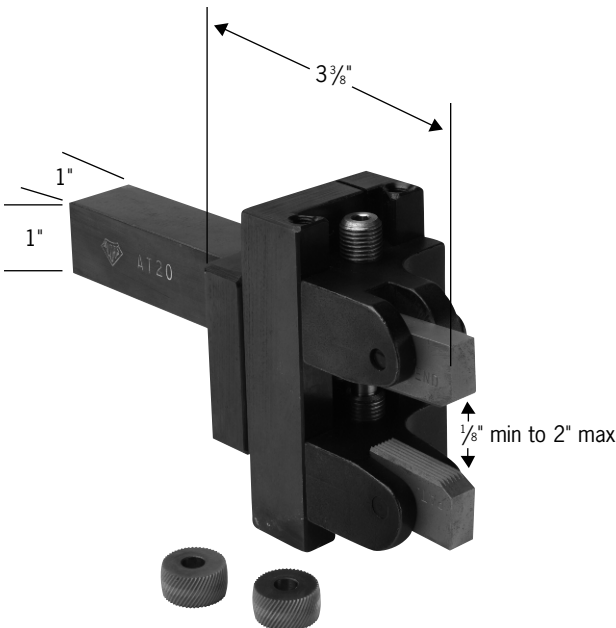

...mounts into tool slot on CNC turrets easily adjustable with knurls installed the range is 1/8"-2". Opposing forces on knurls create little or no force on the machine. Just remove the two knurl lock screws, replace with bar grippers and use as a heavy duty bar puller. There are **no** gripper springs to remove when changing bar diameters. Just loosen the lock screw, insert allen wrench and dial to the next size, preload approximately 1/8 rev., lock locking screw. Furnished with 1" shank without knurls or grippers. Minimum clearance required between turret and covers is 3/8".

ORDER #	AT-20
PRICE - EACH	\$335.00

BAR GRIPPERS

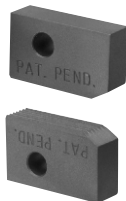

GRIPPER ORDER # (pair)	AT-20G*
PRICE - PAIR	\$87.00

HIGH SPEED KNURLS

For #10, #19, #20 Holders:
AD-Diamond/AS-Straight/NEW - Convex
Hi-Cobalt (ACD-Spiral & ACS-Straight)

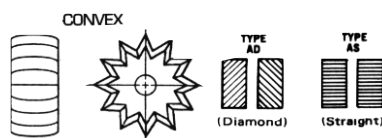

KNURL ORDER #	AD16R/AD16L/AS16* ACD16R/ACD16L/ACS16*	AD20R/AD20L/AS20/AD25R* AD25L/AS25/ACD20R/ACD20L* ACS20/ACD25R/ACD25L/ACS25*	AD50R/AD50L/AS50* ACD50R/ACD50L/ACS50*
	COARSE	MEDIUM	FINE
PRICE EA.	16.00 AD & AS		
	38.00 ACD & ACS (NEW) TIN COATED		

KNURL-LOCK SCREW

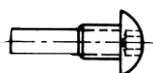

ORDER #	SCR-10*	Used with any #10, #19 and #20 holder
PRICE EA.	\$6.00	